

VT855i & VT855ii / Data Center Monitoring Unit



Documentation page: <https://vutlan.atlassian.net/wiki/spaces/DEN/pages/2604007425/VT855i+VT855ii+Data+Center+Monitoring+Unit>

Product page: <https://vutlan.com/remote-monitoring-units/160-vt855i-data-center-monitoring-unit.html>

Brochure: product version 1.2

Function and purpose

The unit is used for environmental monitoring (e.g. temperature, humidity, voltage, leakage, smoke, airflow). It is also used as an I/O controller (e.g. door control, fans, generator, control panels, UPS, circuit breakers, alarms). Can use up to 1000 different elements - notifications, triggers, timers, logic schemes, sensors, dry contacts. Has built-in Web interface with virtual sensors, logic schemes, different types of notification, and control panels. Has a slot for an LTE modem for an ethernet connection reservation.

Two order options:

VT855i has only x1 power inlet.

VT855ii has x2 power inlets, providing a redundant power supply for A&B power distribution.

Order options / Dimensions

System	Description
VT855i	x1 230V AC power inlet.
VT855ii	x2 230V AC power inlets, providing a redundant power supply for A&B power distribution.
VT855iDC	x1 230V AC and x1 24-48V DC power inlets.
VT855DC	x1 24-48V DC power inlet.
VT855DCDC	x2 24-48V DC power inlets.

S
y
s
t
e
m

Diagram

V
T8
55i

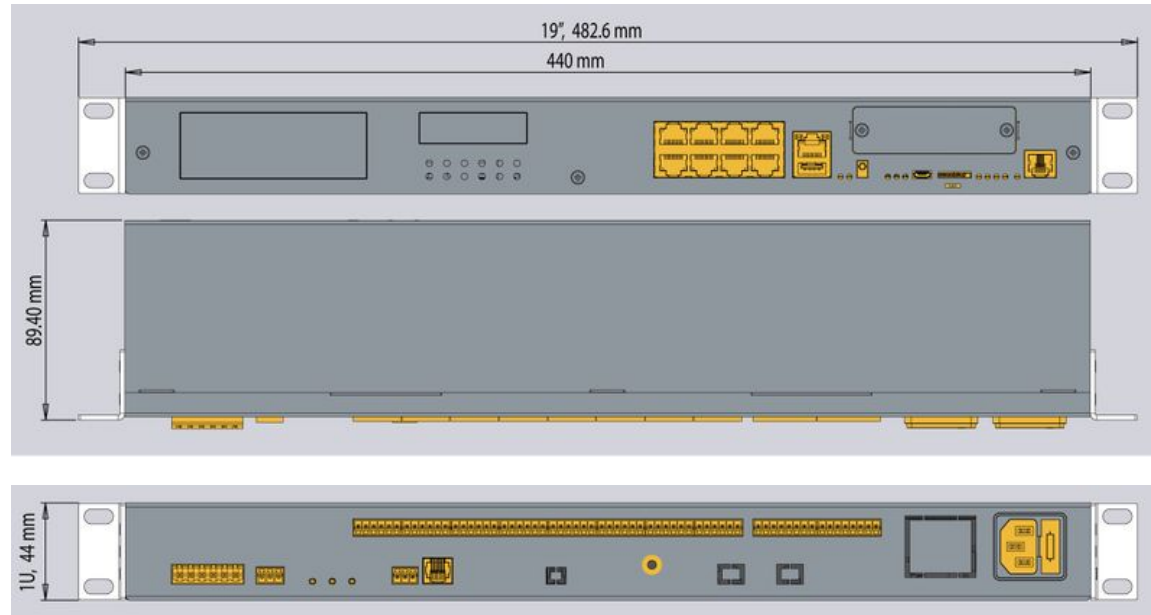

V
T8
55
ii

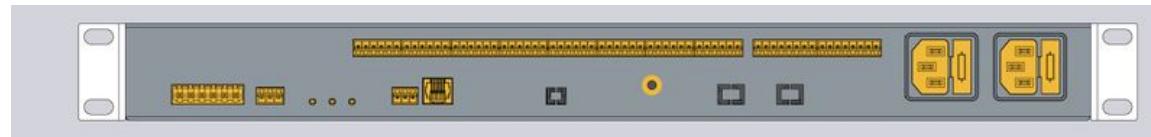

V
T8
55
iDC



V
T8
55
DC

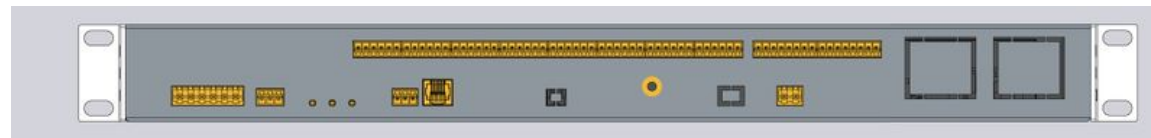

V
T8
55
D
C
DC



Physical Description

The front panel for VT855i & VT855ii:

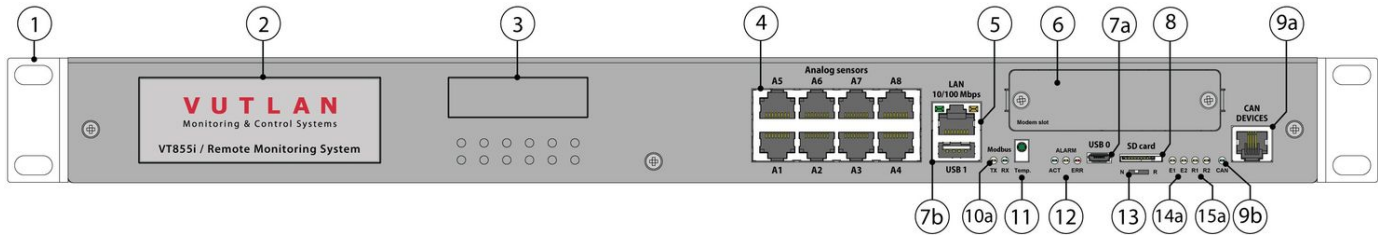

VT855i back panel:

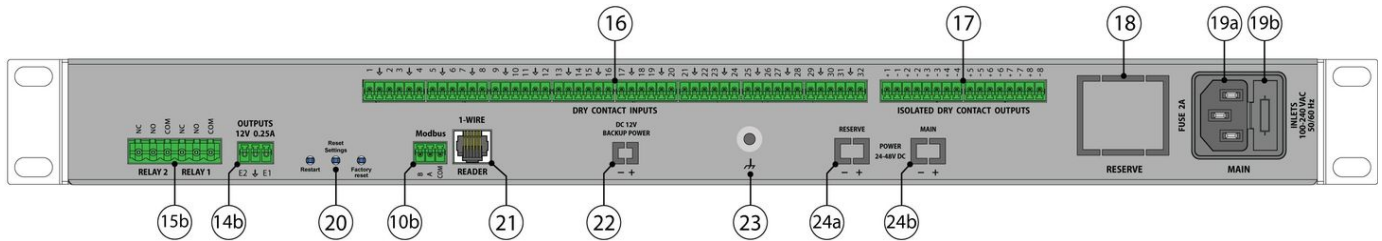

VT855ii back panel:

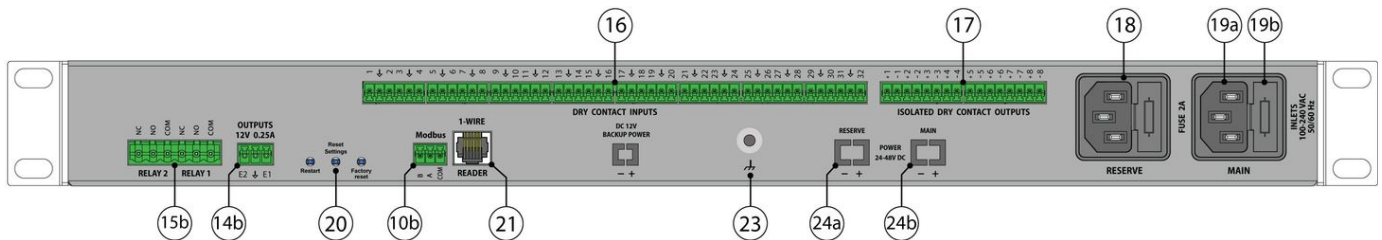

VT855DCDC back panel:

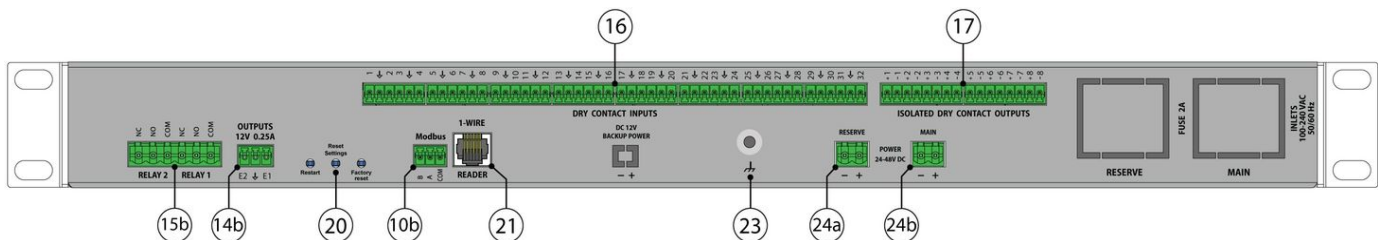

1. "1U 19 inch brackets" - x2 pcs for mounting brackets into a 1U 19" rack slot.
2. "Logo sticker" - Displays article number of the monitoring unit.
3. "Sticker space" - A place for a sticker, can be used by a user to place an identifier of the system (for example, an IP address).
4. "Analog sensors: A1..A8" - 8 RJ12 analog sensor inputs with auto-sensing. Read instructions at "[Analog sensors connection](#)", "[Sensor configuration](#)".
5. "LAN port" - Ethernet 10/100 Base-T port, provides an Ethernet connection. Read more in this section "[LAN, GSM, LTE, RADIUS, DNS, SSL, VPN](#)".
 - "Orange LED" - orange LED for Ethernet port. It shows network traffic.
 - "Green LED" - green LED for Ethernet port. It shows network traffic. Flashes green when the system starts up. Shows the connection state (constant green light - the connection is established, blinking green - the connection attempt).
6. "Modem slot" - "VT790 / LTE modem" can be installed in this slot. *This modem is ordered separately. Read instructions at "[V T790 / LTE modem](#)", "[LAN, GSM, LTE, RADIUS, DNS, SSL, VPN](#)".*

7. USB ports are needed for USB camera recording, USB Flash for system logs, and for the system restore. Read instructions at ["Connecting USB camera"](#), ["USB camera settings. How to save a video"](#), ["Saving system logs on USB flash drive"](#), ["USB upgrade or restore of default settings"](#).

- a. **"USB 0"** - type micro USB-port 2.0, required to connect a USB camera.
- b. **"USB 1"** - type USB-port 2.0, required to connect a USB camera or a USB Flash card.

8. **"SD card"** - MicroSD card slot with an ejector. The card is needed for data storage or for the "system restore". Read instructions at ["Saving system logs to SD card"](#), ["Restore of the appliance \(for VT960 series\)"](#).

9a. **"CAN DEVICES"** - digital connector RJ12 for the connection of CAN sensors/extensions/devices on a CAN bus. Modules can be chained together. Read instructions at ["CAN devices connection"](#), ["Setting up CAN"](#).

- **"LED: CAN"** - green LED indicates CAN bus status.
- The LED blinks slowly - nothing is connected
- The LED blinks fast - configuration is in process
- The LED glows constantly - connected to CAN devices

10ab. **Modbus port** for Modbus RTU devices/meters/sensors with reading/write functionality. Read instructions at ["Connecting Modbus RTU sensors to VT336 & VT336PoE"](#), ["Configuring Modbus devices"](#).

- LED: **"LED: TX"** - Modbus data sent activity (Transmission).
- LED: **"LED: RX"** - Modbus data received activity (Receiving).
- **"MODBUS"** - port for connecting Modbus RTU / RS-485 sensors and devices.

11. **"TEMPERATURE SENSOR"** - accuracy +/- 1 °C.

12. **"LED: ACT"** - green LED indicates appliance system status,

- - operating mode of the device: switches at a frequency of 2 times per second;
- - successful completion of the software update process: switches at a frequency of 4 times per second;

"LED: ALARM" - The button can be programmed from the interface for alarm indicating.

"LED: ERR" - red LED indicates error and traffic.

- the operating mode of the device: If everything is normal, the LED is extinguished, if not - there's a constant glow;
- software update mode: switches at a rate of 2 times per second;

13. **"Dip switch"**

- Normal mode: The switch is switched to the left . The switch should be always in this position.
- Recovery mode: The switch is switched to the right . Use this option only in case you need to recover manufacturing settings.

14a. **"OUTPUTS 12V 0.25A"** - 12V 0.25A (for each output) terminals outputs (electronic relay). Read instructions at ["Connecting 12V devices to 12V outputs"](#).

- **"LEDs: E1, E2"** - status indicators for two 12V 0.25A outputs.
- The LED is ON (orange) - the output is ON (the initial state can be configured).
- The LED is OFF (orange) - the output is OFF ((the initial state can be configured).

15. **"Relays 1, Relay 2"** - NC / NO power relay terminals. Read instructions at ["Connecting NC/NO relays"](#), ["A relay switching \(NC NO\)"](#), ["Relays \(Outlets\) \(SNMP\)"](#).

- **"LEDs: R1, R2"** - status indicators for x2 relays at the back of the unit.
- The LED is ON (orange) - the relay is ON (the initial state can be configured).
- The LED is OFF (orange) - the output is OFF ((the initial state can be configured).

16. **"DRY CONTACT INPUTS 1...32"** - Digital inputs (Type IN). Read instructions at ["Connecting dry contacts"](#), ["Dry contacts settings"](#).

17. **"ISOLATED DRY CONTACTS OUTPUTS 1...8"** - Digital outputs 24VDC / 15mA (type OUT). Read instructions at ["Connecting dry contacts"](#), ["Dry contacts settings"](#).

18/19. Please refer to section "Order options" in this document.

- 18. **"RESERVE"** - Reserve power inlet. 100-240VAC, 50/60Hz, Fuse 2A, Fuse 5x20mm, type C14.
- 19. **"MAIN"** - Power inlet. 100-240VAC, 50/60Hz, Fuse 2A, Fuse 5x20mm, type C14.

20. Buttons

- 9a. **"Restart"** - the button restarts the appliance. Hold the button for 2 seconds and then let go, the system will restart.
- 9b. **"Reset settings"** -
- 9b. **"Factory reset"** -

21. **"1-WIRE READER"** - For connecting RFID reader or 1-Wire sensors. A serial communication protocol that uses a single data line plus ground reference between master and 1-Wire slave devices. Read instructions at "[Connecting 1-Wire devices](#)", "[Access control](#)", "[Setting up 1-Wire](#)".
22. **"DC 12V BACKUP POWER"** - optional order option. Only available for custom orders.
23. **"Chassis grounding"** - Chassis grounding, M4 thread. Enhances the immunity of the equipment against conducted and radiated RF disturbances. Please contact a professional electrician before connecting it.
24. **"POWER 24-48V DC"** - optional order option for some of the units. Please refer to section "Order options" in this document.
 - 24a. **"RESERVE"** - Reserve power inlet. 24-48V DC, 5.08mm 2EDGK power plug, 18-72VDC to 12VDC/0.84A
 - 24b. **"MAIN"** - Power inlet. 24-48V DC, 5.08mm 2EDGK power plug, 18-72VDC to 12VDC/0.84A

Connection overview diagram

The front panel of **VT855i & VT855ii**:

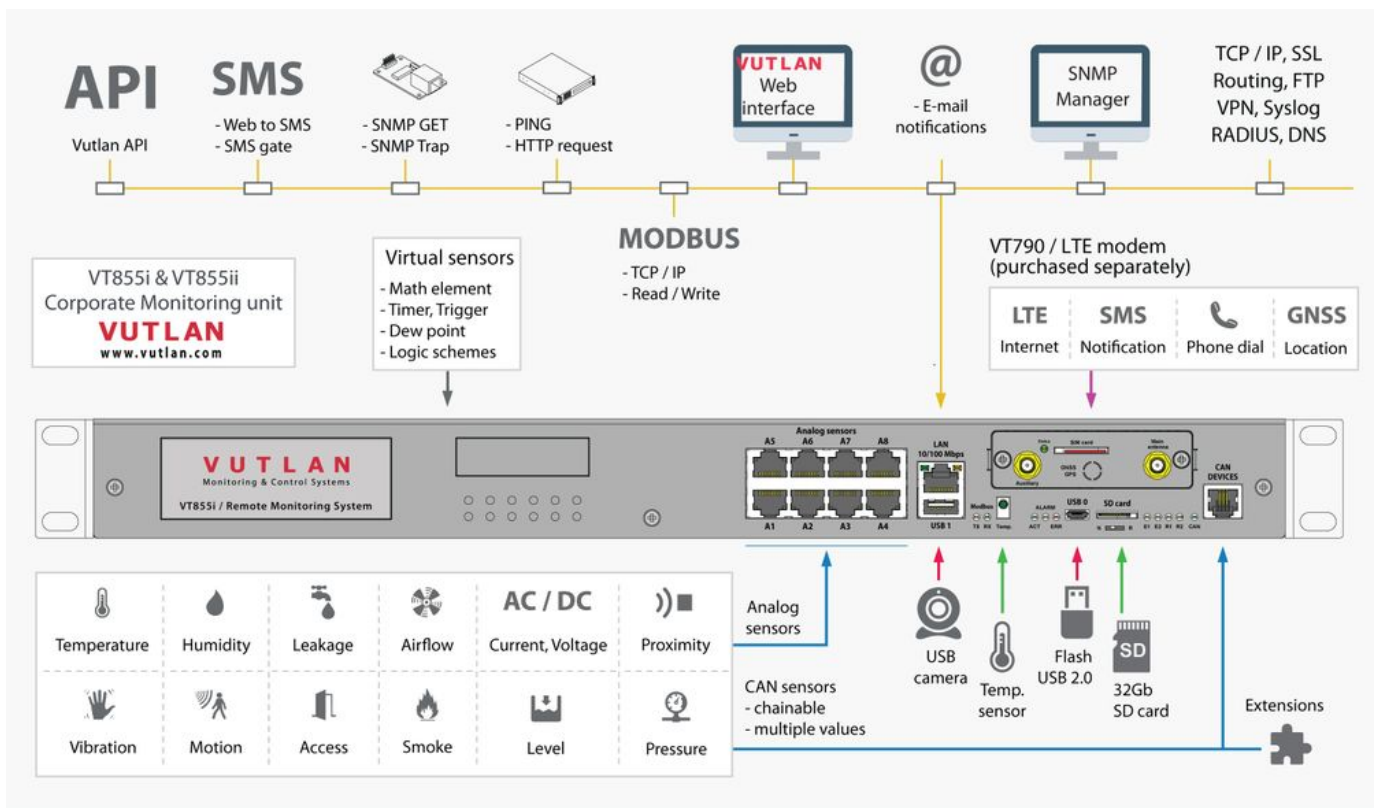

The back panel of **VT855ii**:

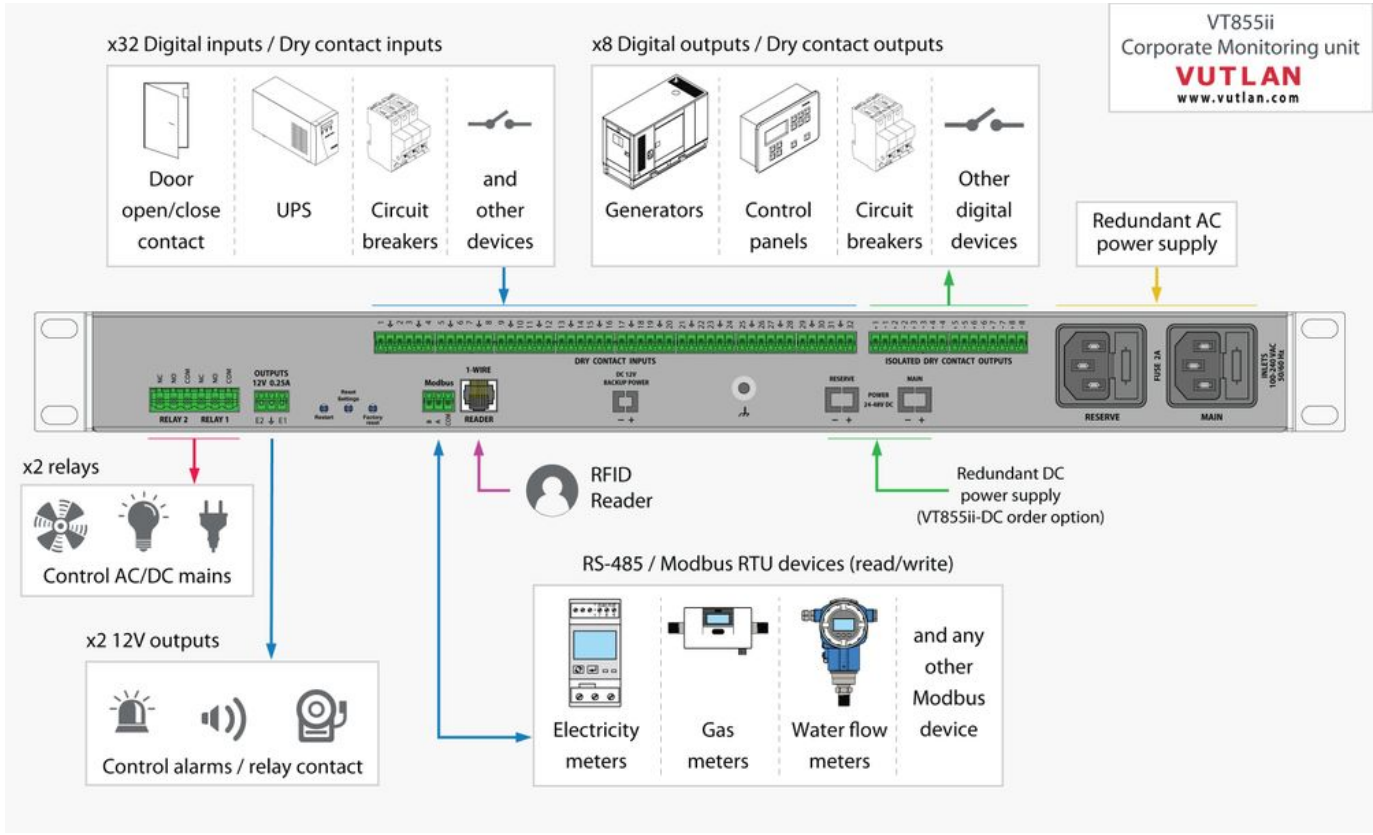

Drawing dimensions

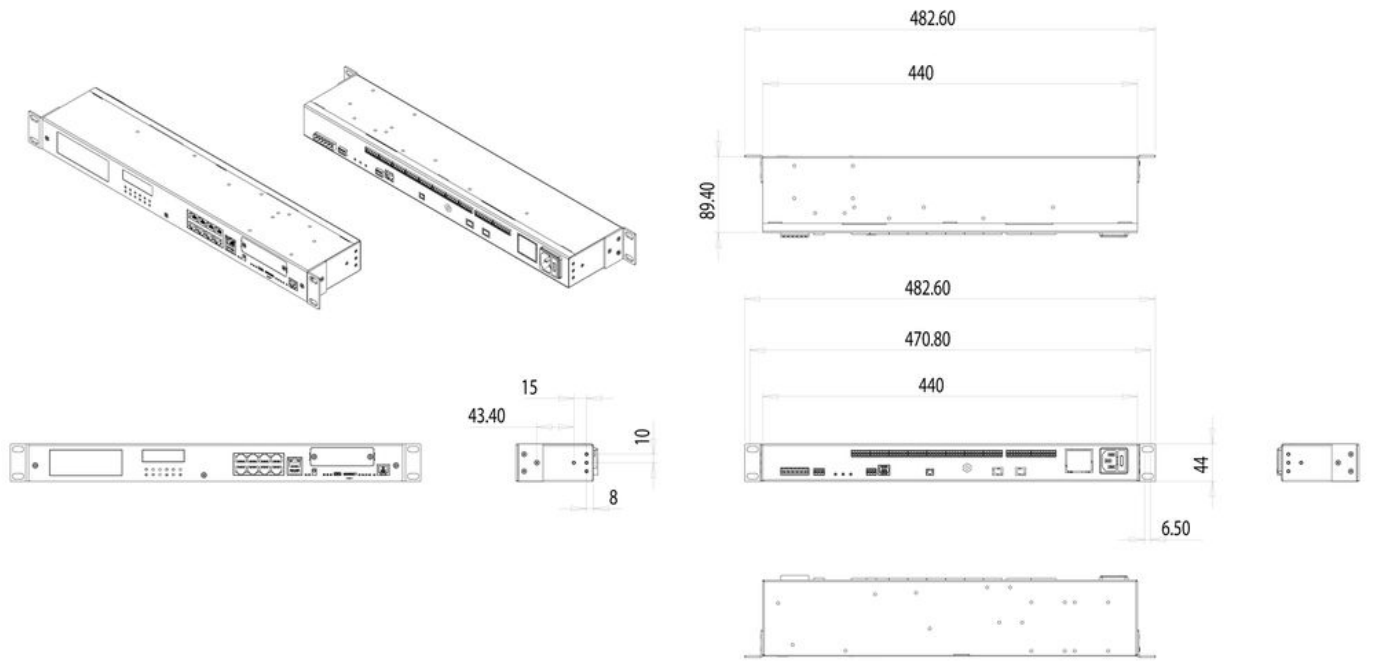

Installing the device into a 19" rack

Use x3 pcs of supplied screws (M3 6mm) for each bracket to fix it on each side of the enclosure as shown in the picture below. The screws and brackets are supplied with the unit.

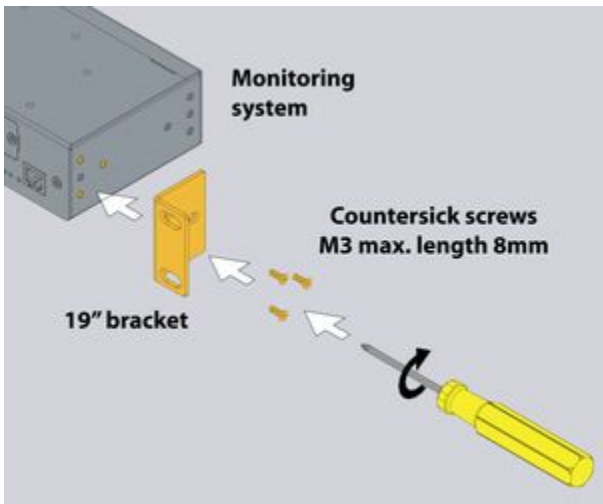
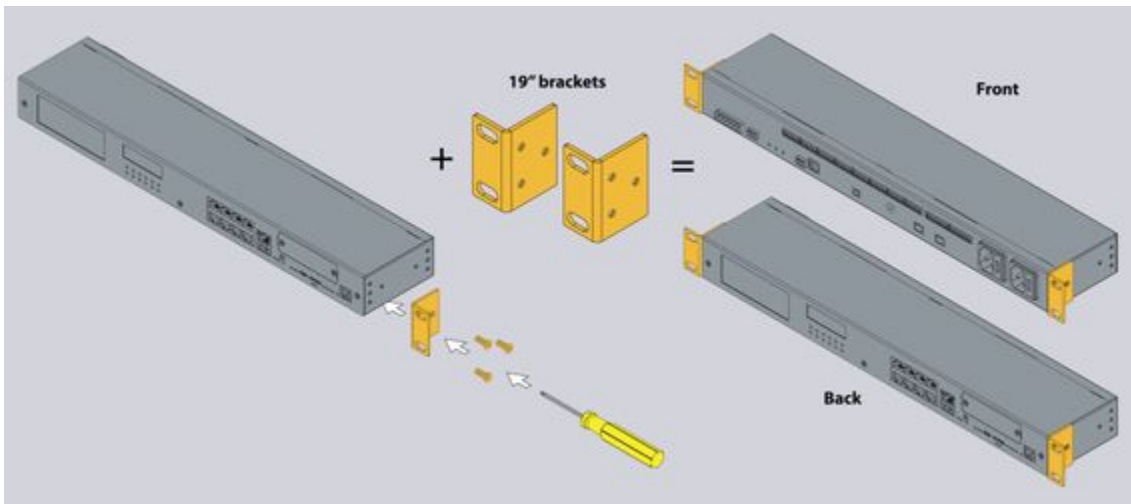

Installing LTE slot modem

Product page: <https://vutlan.com/modems/155-vt790-lte-slot-modem.html>

Datasheet page: <https://vutlan.atlassian.net/wiki/spaces/DEN/pages/2309947438/VT790+LTE+modem>



Usage

Can be installed in VT900i, VT900ii, VT855, VT825i, VT835i monitoring systems.

Description

4G LTE slot modem for Vutlan monitoring units. Allows to receive and send SMS messages. Provides Ethernet over 4G LTE. Power-cycling is an embedded function.

Panel

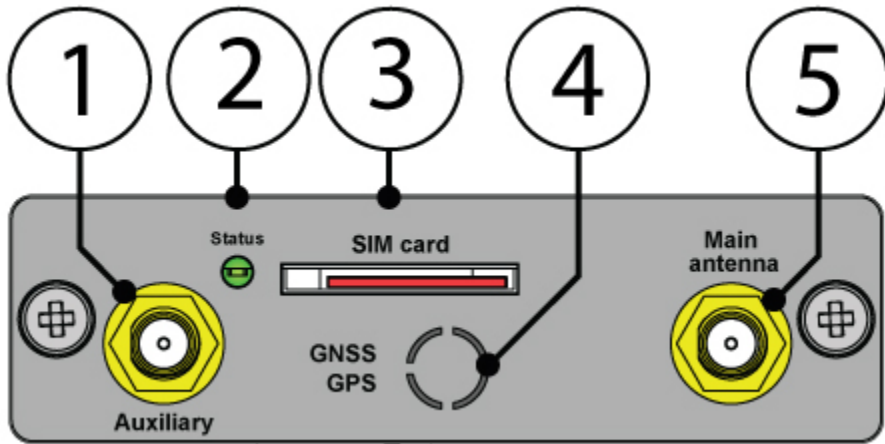

1. "**Auxiliary**" - Connector, used when the modem is installed inside of the appliance to connect LTE auxiliary antenna. The additional antenna helps to strengthen the signal level. (Auxiliary LTE antenna and antenna output are ordered separately from the modem).
2. "**Status**" - displays modems status. Blinking = working.
3. "**SIM card**" - SIM card slot with an injector.
4. "**GPS active antenna**" - Connector, used when the modem is installed inside of the appliance to connect GNSS antenna (GPS antenna with tail is ordered separately from the modem). (Currently not supported)
5. "**Main antenna**" - Connector, used when the modem is installed inside of the appliance to connect GSM or LTE main antenna. (The main antenna is supplied together with the modem).

Installation

You can install the modem while the system is turned On. You may wait up to 3 minutes until the Telecom operator information is renewed.

Step 1

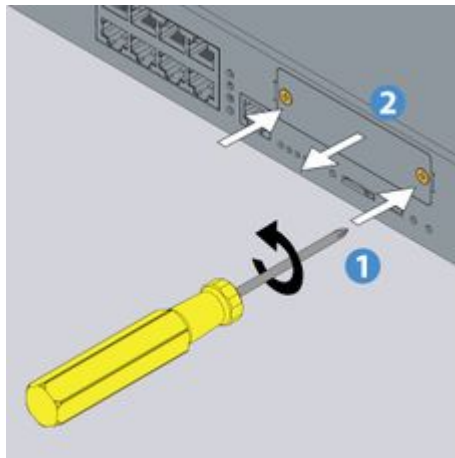



1.1 Unscrew the two screws holding the front panel called "**Modem slot**". Keep the screws, you will need them in Step 3.

1.2 Take the panel out and put it away.

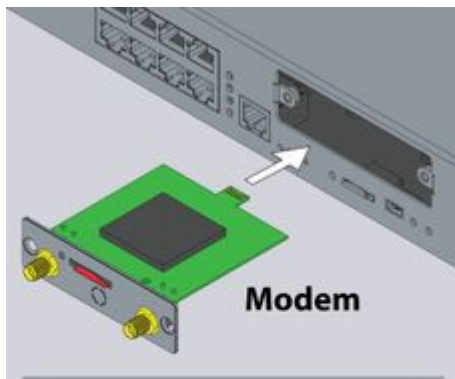
Step 2

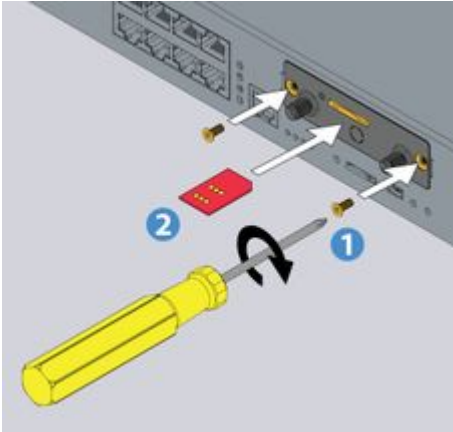
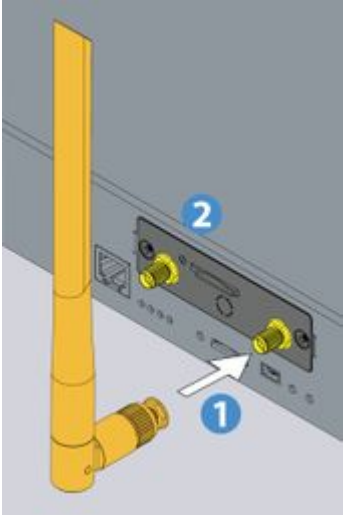

Plug the modem as shown on the picture into the opening. The board should slide into the guide rails (marked as "1") and plug into the jack (marked as "2").

		
Step 3		<p>3.1 Use the screws we unscrewed earlier and screw them in clockwise, securing the new modem in place.</p> <p>3.2 Plug in the SIM card. The SIM card slot has an injector.</p>
Step 4		<p>4.1 Screw the main LTE antenna into "Main" antenna" jack.</p> <p>4.2 If you want to strengthen the signal, you can plug the second auxiliary antenna into "Auxiliary" jack.</p>
Step 5		<p>You are ready to go! Turn on the system.</p>

If you want to unmount the modem, you can unscrew the screws and just pull it out using x2 gold-plated antenna jacks.

Configuring the modem

Please read the following section for the configuration instructions:



Online documentation page link: [Setting up a modem](#)



The direct page link for users with paper documentation:



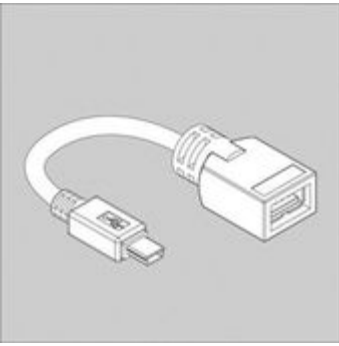

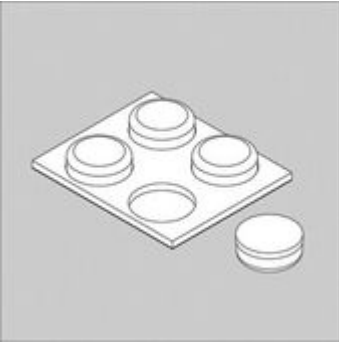
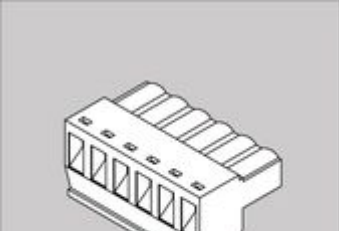
<https://vutlan.atlassian.net/wiki/spaces/DEN/pages/1016347/Setting+up+a+modem>

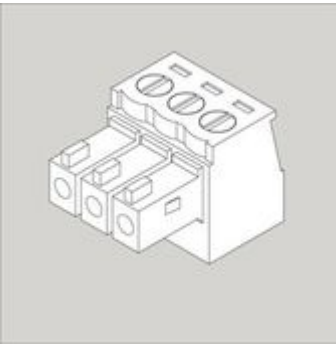
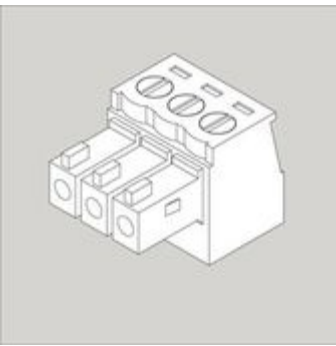
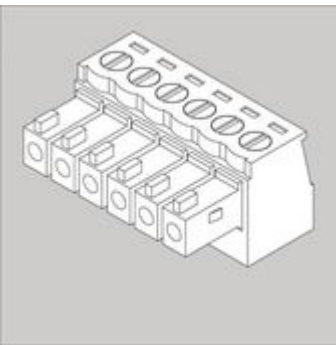
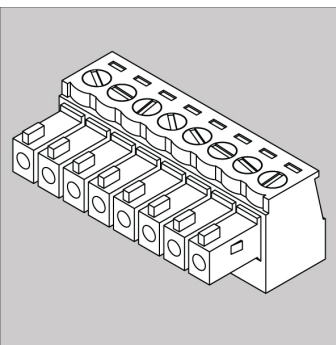
Inventory

Make sure that the contents of the delivery meet the following configuration. Report a missing or damaged component to your supplier. If damage occurred during transportation, contact the appropriate delivery service.

	Package content	Description	Quantity				
			VT855i	VT855ii	VT855iDC	VT855DC	VT855DCDC
1		Monitoring unit VT825.	1 pc				
2		OTG USB cable adapter	1 pc				
3		RJ-45 3m patch cable. For LAN Ethernet connection.	1 pc				
4		Self-adhesive rubber foot	4 pcs				
5		Terminal plug 6 pins, 5.08mm, 6P. For NC NO COM relays.	1 pc				

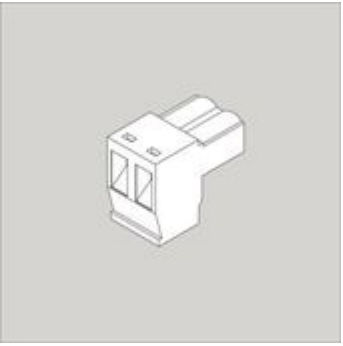
			
6		Terminal plug 3 pins, 3.81 mm. For 12V relays (E1 & E2).	1 pcs
7		Terminal plug 3 pins, 3.5 mm. For Modbus port.	1 pcs
8		Terminal plug 6 pins, 3.5 mm. For connecting dry contact inputs.	8 pcs
9		Terminal plug 8 pins, 3.5 mm. For connecting dry contact outputs.	2 pcs
10		Configuration manual	1 pc

								
11		Warranty card						1 pc
				VT855i	VT855ii	VT855iDC	VT855DC	VT855DCDC
12		Terminal plug 2 pins, 5.08mm, 2P. For power input 24-48VDC.		-	-	1 pc	1 pc	2 pc
13		EU Schuko C13 0.75 mm ² . 230V 10A cable.	1 pc	2 pc	1 pc	-	-	-

Transparent plastic bag 70x125mm:

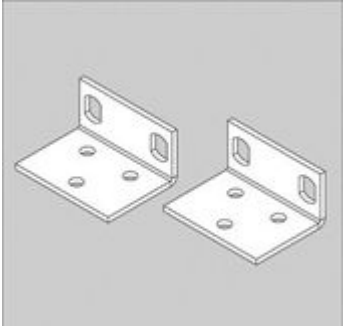
	Package content	Description	
1		19" rack brackets	2 pcs

2		M3 x 8mm Phillips flat-head screws (transparent plastic bag 42x70mm)	6 pcs
---	---	---	-------

Technical details

VT325, VT335, VT825, VT855i, VT960i, VT960ii are the monitoring units and can not connect to each other. For scalability please use extension units and embedded boards. All units except produced in DC / DC version.

- Built-in
- None
- ◇ Extension possible
- ◇ Not extendable

Versions	VT960i / VT960ii DC/DC; AC/DC	VT855i / VT855ii DC/DC; AC/DC	VT825i / VT825ii DC/DC; AC/DC	VT335i	VT336	VT335	VT325
Device Management: Web, SNMP, manually via SMS	●	●	●	●	●	●	●
Interface	VT960i	VT855i	VT825i	VT335i	VT336	VT335	VT325
LAN: Ethernet 10/100 Mbit	●	●	●	●	●	●	●
OS: Linux	v.5.10	v.5.40	v.5.40	v.5.40	v.3.10	v.3.10	v.3.10
RAM:	1Gb	128Mb	128Mb	64Mb	64Mb	64Mb	64Mb
CPU speed:	720mHz	600mHz	600mHz	600mHz	300mHz	300mHz	300mHz
Clock: Built-in clock	●	●	●	●	●	●	●
Watchdog: Built-in watchdog timer							
Max. amount of sensors: physical sensors, dry contacts, relays	400	150	150	100	30	30	6
Max. amount of elements: notifications, triggers, timers, logic, sensors, dry contacts, SNMP Get, SNMP Trap, and other elements	2000	1000	1000	700	500	500	500
Protocol support	VT960i	VT855i	VT825i	VT335i	VT336	VT335	VT325
Network protocols: DHCP; HTTP; HTTPS; DynDNS; SSL/TLS; SNMP v1, v2c, v3; SMTP; FTP; Syslog; RADIUS; Modbus RTU; OpenVPN	●	●	●	●	●	●	●
VPN: secure data communications; secure change of connection between LTE and LAN	●	●	●	●	●	●	●
SSH: Provided as a separate patch.					□	□	□
Alerts / Notifications	VT960i	VT855i	VT825i	VT335i	VT336	VT335	VT325
Alert types: E-mail, FTP log, Syslog, SMTP, SNMP Traps, SMS (Modem is ordered separately), Web-to-SMS, PUSH	●	●	●	●	●	●	●
A maximum number of "mail to" recipients in an E-mail notification:	50	20	20	20	10	10	10

A maximum number of "SMS to" recipients in an SMS notification: also the maximum amount of phone numbers	50	20	20	20	10	10	10
Virtual sensors							
	VT960I	VT855I	VT825I	VT335I	VT336	VT335	VT325
Pings: Built-in function for server pinging. Test the reach-ability of a host in a network.	•	•	•	•	•	•	•
IP cameras: Connect the IP MJPEG camera with a proxy via the master module.	4	1	1	1	1	1	1
Get SNMP: Read data from external equipment via SNMP PDU GET (v1 /2c)	•	•	•	•	•	•	•
User keys: Add users who have access using RFID reader.	•	•	•	•	•	•	•
Logic schemes: Used to specify automatic actions to events that occur in the system.	•	•	•	•	•	•	•
Timers: Allows you to plan the events in the system.	•	•	•	•	•	•	•
Triggers: Generate events in the system if logic is triggered.	•	•	•	•	•	•	•
Push notifications	•	•	•	•	•	•	•
SNMP traps	•	•	•	•	•	•	•
Virtual Math element (combine several sensor data and calculate new data)	•	•	•	•	•	•	•
Logic schemes	•	•	•	•	•	•	•
Modbus TCP/IP: read / write	•	•	•	•	•	•	•
Power							
	VT960I	VT855I	VT825I	VT335I	VT336	VT335	VT325
Power input:	90-230V	90-230V	90-230V	12V	12V	12V	12V
Power input DC:	24 ÷ 48V	24 ÷ 48V	24 ÷ 48V	12V	□	24 ÷ 48V	□
Fuse: Fuse at the inlet	1A	1A	1A	1A	□	□	□
Max. power consumption:	30W	30W	10W	10W	12W	10W	6W
The maximum current load on the relay:	10A	10A	250mA	250mA	250mA	250mA	250mA
Redundant power supply: built-in voltage monitor, voltage range 9-12.6 V.	Yes AC/DC DC/DC	Yes AC/DC DC/DC	Yes AC/DC DC/DC	Yes DC 12V	□	□	□
Outputs							
	VT960I	VT855II	VT825I	VT335I	VT336	VT335	VT325
Relay outputs: latching relays 240V*10A	2	2	□	□	□	□	□
Relays outputs: 12V 0.25A	2	2	2	2	2	2	2
Max. dry contact outputs (contact closures/digital outputs)	8	8	□	□	□	□	□
Audio output: AV OUT	1	□	□	□	□	□	□
Video output: AV OUT	1	□	□	□	□	□	□
Inputs							
	VT960I	VT855I	VT825I	VT335I	VT336	VT335	VT325
Analog port: 6P6C for connection of any analog sensor.	8	8	8	4	6	4	2
CAN port: Max number of sensors Use CAN-12V-1A for connecting more than 12 devices.	32	32	32	32	20	20	□
Dry contact inputs:	32	32	16	4	4	4	□

Modbus: (Max. 32 sensors, Max. line length 1000m)	1	1	□	□	•		
Reader 1-Wire	1	1	□	□	□	□	□
Video							
	VT960I	VT855I	VT825I	VT335I	VT336	VT335	VT325
Video cameras:	AV, USB, x4 IP	USB, x1 IP	USB, x1 IP	USB, x1 IP	USB, x1 IP	USB, x1 IP	USB, x1 IP
Video power supply: DC 12V 0,25A for analog camera	•	□	□	□	□	□	□
Other connectors							
	VT960I	VT855I	VT825I	VT335I	VT336	VT335	VT325
Ethernet port: 10/100Mbit	•	•	•	•	•	•	•
USB 2.0 Type A	1	1	1	□	□	□	□
USB 2.0 micro	1	1	1	1	1	1	1
Switch Normal / Recovery: returns the device to factory settings	□	□	□	□	•	•	•
FEL button: softly restarts SATA drive	•	□	□	□	□	□	□
Shutdown button: Softly shuts down the device.	•	□	□	□	□	□	□
External Memory							
	VT960I	VT855I	VT825I	VT335I	VT336	VT335	VT325
SD card slot	•	•	•	•	□	□	□
SATA Drive: 2.5" HDD or SSD (ordered separately)		◇	◇	◇	◇	◇	◇
Extensions (modules are ordered separately)							
	VT960I	VT855I	VT825I	VT335I	VT336	VT335	VT325
SATA: 2.5" HDD or SSD (ordered separately)		◇	◇	◇	◇	◇	◇
Modem (extensions)							
	VT960I	VT855I	VT825I	VT335I	VT336	VT335	VT325
4G LTE modem: ordered separately.	VT790	VT790	VT740	VT740	VT770	VT760	□
GSM modem: ordered separately	□	□	□	□	□	VT700	□
Modem modes:	Gateway / Access / SMS	Gateway / Access / SMS	Gateway / Access / SMS	Gateway / Access / SMS	Access / SMS	Access / SMS	SMS (external modem)
<ul style="list-style-type: none"> • Gateway: Internet access • Access: Internet access over LTE • SMS: SMS notifications 							
Embedded sensors							
	VT960I	VT855I	VT825I	VT335I	VT336	VT335	VT325
Temperature sensor: +/- 1 °C Case temperature.	•	•	•	•	•	•	•
Power supply voltage sensor: Accuracy (1%)	2	2	2	2	1	1	1
Environmental characteristics							
	VT960I	VT855I	VT825I	VT335I	VT336	VT335	VT325
Operating temperature: -10 to 80 °C	•	•	•	•	•	•	•
Storage temperature: -25 to 85 °C	•	•	•	•	•	•	•
Operating humidity: 0 to 90 %, non-condensing	•	•	•	•	•	•	•
Storage humidity: 0 to 95 %, non-condensing	•	•	•	•	•	•	•

Other Features	VT960I	VT855I	VT825I	VT335I	VT336	VT335	VT325
Installation:	19" 1U	19" 1U	19" 1U	Desktop	DIN rail	Desktop	Desktop
Dimensions (L x W x H) in mm:	440*44*120	440*44*90	440*44*90	180*35*80	160*90*58	180*35*80	95*35*80
Weight:	2 kg	1,5 kg	1,5 kg	0,7 kg	0,4 kg	0,7 kg	0,4 kg
External chassis grounding: M4 thread	•	•	•	•	□	•	•
Web interface (panels)	VT960I	VT960II	VT855I	VT335I	VT336	VT335	VT325
Dashboard panel:	•	•	•	•	•	•	•
System tree panel: sensors and devices displayed in a hierarchy	•	•	•	•	•	•	•
Event log panel:	500 logs	300	300	300	200	200	200
List of latest sent SMS messages:	500	200	200	150	100	100	100
Supported Vutlan environmental sensors							
Temperature, Outdoor Temperature, Humidity, Water leakage, Wind speed meter, Access sensor, Door sensor, Water Level, AC / DC current meters, AC voltage monitor, Smoke detector, Vibration, Motion / PIR, Converter	•	•	•	•	•	•	•

• Built-in □ None Extension possible ◇ Not extendable

Copyright:

Vutlan s.r.o. (LLC)

Remote Infrastructure Monitoring and Control

43 ul.Svornosti, 821 06 Bratislava,

Slovak Republic

www.vutlan.com