

VT855i & VT855ii / Data Center Monitoring Unit

Documentation page:

<https://vutlan.atlassian.net/wiki/spaces/DEN/pages/2604007425/VT855i+VT855ii+Data+Center+Monitoring+Unit>

Product page: <https://vutlan.com/remote-monitoring-units/160-vt855i-data-center-monitoring-unit.html>

Brochure: product version 2.6







Function and purpose

The unit is used for environmental monitoring (e.g. temperature, humidity, voltage, leakage, smoke, airflow). It is also used as an I/O controller (e.g. door control, fans, generator, control panels, UPS, circuit breakers, and alarms). Can use up to 1000 different elements - notifications, triggers, timers, logic schemes, sensors, dry contacts. Has a built-in Web interface with virtual sensors, logic schemes, different types of notifications, and control panels. Has a slot for an LTE modem for an ethernet connection reservation.

Order options / Dimensions

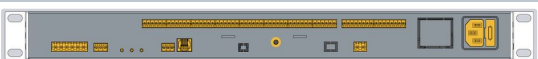
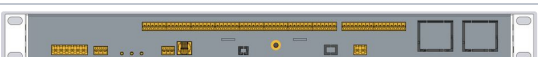
System	Description
VT855i	x1 230V AC power inlet.
VT855ii	x2 230V AC power inlets, providing a redundant power supply for A&B power distribution.
VT855iDC	x1 230V AC and x1 24-48V DC power inlets.
VT855DC	x1 24-48V DC power inlet.
VT855DCDC	x2 24-48V DC power inlets.

System	Diagram
VT855i	
VT855ii	
VT855IDC	
VT855DC	
VT855DCDC	

Physical Description

The front panel for VT855i & VT855ii:

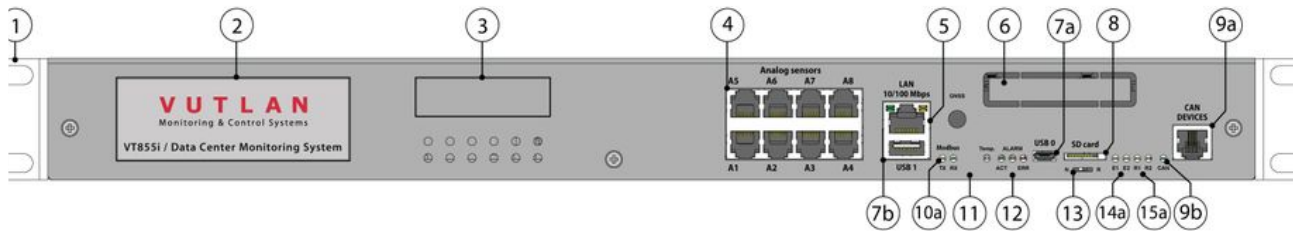

VT855i back panel:

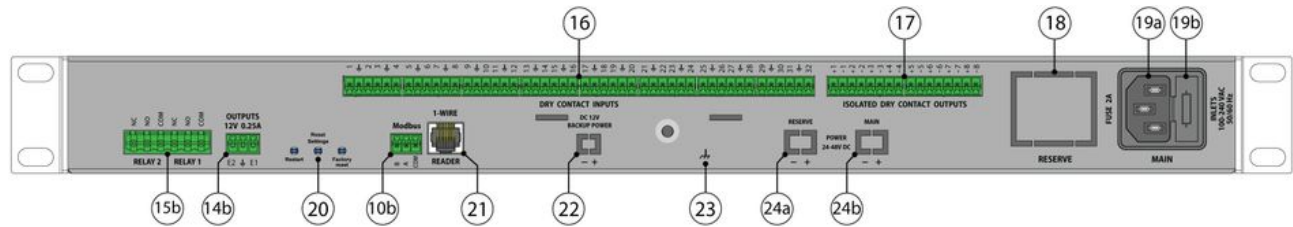

VT855ii back panel:

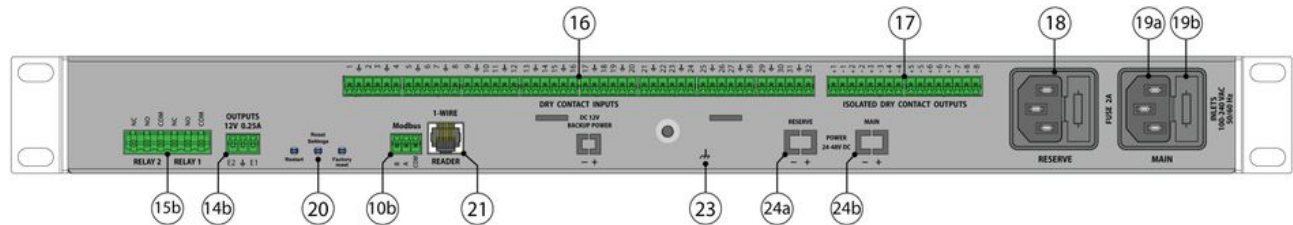

VT855DCDC back panel:

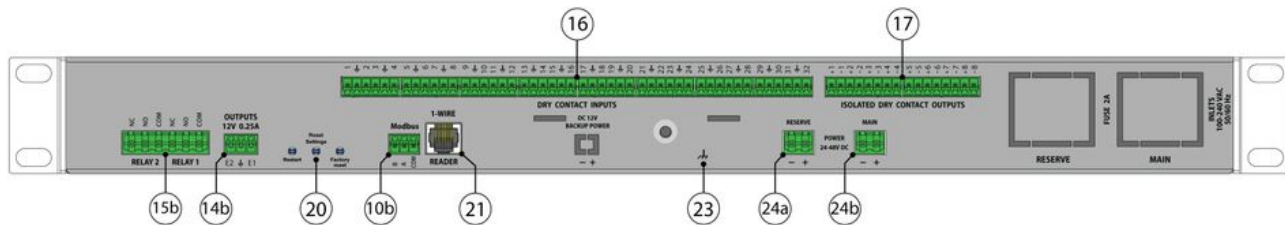

1. "1U 19-inch brackets" - x2 pcs for mounting brackets into a 1U 19" rack slot.
2. "Logo sticker" - Displays the article number of the monitoring unit.
3. "Sticker space" - A place for a sticker, can be used by a user to place an identifier of the system (for example, an IP address).
4. "Analog sensors: A1..A8" - 8 RJ12 analog sensor inputs with auto-sensing. Read instructions at ["Analog sensors connection"](#), and ["Sensor configuration"](#).
5. "LAN port" - Ethernet 10/100 Base-T port, provides an Ethernet connection. Read more in this section ["LAN, GSM, LTE, RADIUS, DNS, SSL, VPN"](#).
 - "Orange LED" - orange LED for Ethernet port. It shows network traffic.
 - "Green LED" - green LED for Ethernet port. It shows network traffic. Flashes green when the system starts up. Shows the connection state (constant green light - the connection is established, blinking green - the connection attempt).
6. "Modem slot" - "VT740 / LTE slot modem" can be installed in this slot. *This modem is ordered separately. Read instructions at ["VT740 / LTE slot modem"](#), and ["LAN, GSM, LTE, RADIUS, DNS, SSL, VPN"](#).*
7. USB ports are needed for USB camera recording, USB Flash for system logs, and system restoration. Read instructions in ["Connecting USB camera"](#), ["USB camera settings. How to save a video"](#), ["Saving system logs on USB flash drive"](#), and ["USB upgrade or restore of default settings"](#).
 - a. "USB 0" - type micro USB-port 2.0, required to connect a USB camera.
 - b. "USB 1" - type USB-port 2.0, required to connect a USB camera or a USB Flash card.
8. "SD card" - MicroSD card slot with an ejector. The card is needed for data storage or the "system restore". Read the instructions at ["Saving system logs to SD card"](#), and ["Restore the appliance \(for VT960 series\)"](#).
- 9a. "CAN DEVICES" - digital connector RJ12 for the connection of CAN sensors/extensions/devices on a CAN bus. Modules can be chained together. Read the instructions in ["CAN devices connection"](#), and ["Setting up CAN"](#).
 - "LED: CAN" - green LED indicates CAN bus status.
 - The LED blinks slowly - nothing is connected
 - The LED blinks fast - configuration is in process
 - The LED glows constantly - connected to CAN devices
- 10ab. **Modbus port** for Modbus RTU devices/meters/sensors with reading/write functionality. Read instructions in ["Connecting Modbus RTU sensors to VT336 & VT336PoE"](#), and ["Configuring Modbus devices"](#).
 - LED: "LED: TX" - Modbus data sent activity (Transmission).
 - LED: "LED: RX" - Modbus data received activity (Receiving).
 - "MODBUS" - port for connecting Modbus RTU / RS-485 sensors and devices.
11. "TEMPERATURE SENSOR" - Accuracy +/- 1 °C.
12. "LED: ACT" - green LED indicates appliance system status,
 - - operating mode of the device: switches at a frequency of 2 times per second;

- - successful completion of the software update process: switches at a frequency of 4 times per second;

"LED: ALARM" - The button can be programmed from the interface for alarm indication.

"LED: ERR" - red LED indicates error and traffic.

- the operating mode of the device: If everything is normal, the LED is extinguished, if not - there's a constant glow;
- software update mode: switches at a rate of 2 times per second;

13. "Dip switch"

- Normal mode: The switch is switched to the left ←. The switch should be always in this position.
- Restore of appliance: The switch is switched to the right →. Used to load the clean system image from an SD card. Read instructions at "<https://vutlan.atlassian.net/wiki/spaces/DEN/pages/2417491974>".

14a. "OUTPUTS 12V 0.25A" - 12V 0.25A (for each output) terminals outputs (electronic relay). Read the instructions at "[Connecting 12V devices to 12V outputs](#)".

- "LEDs: E1, E2" - status indicators for two 12V 0.25A outputs.
- The LED is ON (orange) - the output is ON (the initial state can be configured).
- The LED is OFF (orange) - the output is OFF ((the initial state can be configured).

15. "Relays 1, Relay 2" - NC / NO power relay terminals. Read instructions at "[Connecting NC/NO relays](#)", "[A relay switching \(NC NO\)](#)", and "[Relays \(Outlets\) \(SNMP\)](#)".

- "LEDs: R1, R2" - status indicators for x2 relays at the back of the unit.
- The LED is ON (orange) - the relay is ON (the initial state can be configured).
- The LED is OFF (orange) - the output is OFF ((the initial state can be configured).

16. "DRY CONTACT INPUTS 1...32" - Digital inputs (Type IN). Read the instructions at "[Connecting dry contacts](#)", and "[Dry contacts settings](#)".

17. "ISOLATED DRY CONTACTS OUTPUTS 1...8" - Digital outputs 24VDC / 15mA (type OUT). Read the instructions at "[Connecting dry contacts](#)", and "[Dry contacts settings](#)".

18/19. Please refer to the section "Order options" in this document.

- 18. "RESERVE" - Reserve power inlet. 100-240VAC, 50/60Hz, Fuse 2A, Fuse 5x20mm, type C14.
- 19. "MAIN" - Power inlet. 100-240VAC, 50/60Hz, Fuse 2A, Fuse 5x20mm, type C14.

20. Buttons

- 20a. "Restart" - the button restarts the appliance. Hold the button for 2 seconds and then let go, and the system will restart.
- 20b. "Reset settings" - reset settings to default factory settings. Keep pressing the button for more than 5 seconds. The "ERR" LED will start blinking. This indicates that the factory restoration has started. Wait for 20-60 seconds for the system to restart. The "ACT" LED will start blinking once the system has been restarted. The device can be accessed now.
- 20c. "Factory reset" - Do not use this button.

21. "1-WIRE READER" - For connecting RFID reader or 1-Wire sensors. A serial communication protocol that uses a single data line plus ground reference between master and 1-Wire slave devices. Read instructions at "[Connecting 1-Wire devices](#)", "[Access control](#)", and "[Setting up 1-Wire](#)".

22. "DC 12V BACKUP POWER" - optional order option. Only available for custom orders.

23. "Chassis grounding" - Chassis grounding, M4 thread. Enhances the immunity of the equipment against conducted and radiated RF disturbances. Please contact a professional electrician before connecting it.

24. "POWER 24-48V DC" - optional order option for some of the units. Please refer to the section "Order options" in this document.

- 24a. "RESERVE" - Reserve power inlet. 24-48V DC, 5.08mm 2EDGK power plug, 18-72VDC to 12VDC/0.84A
- 24b. "MAIN" - Power inlet. 24-48V DC, 5.08mm 2EDGK power plug, 18-72VDC to 12VDC/0.84A

Connection overview diagram

The front panel of VT855i & VT855ii:

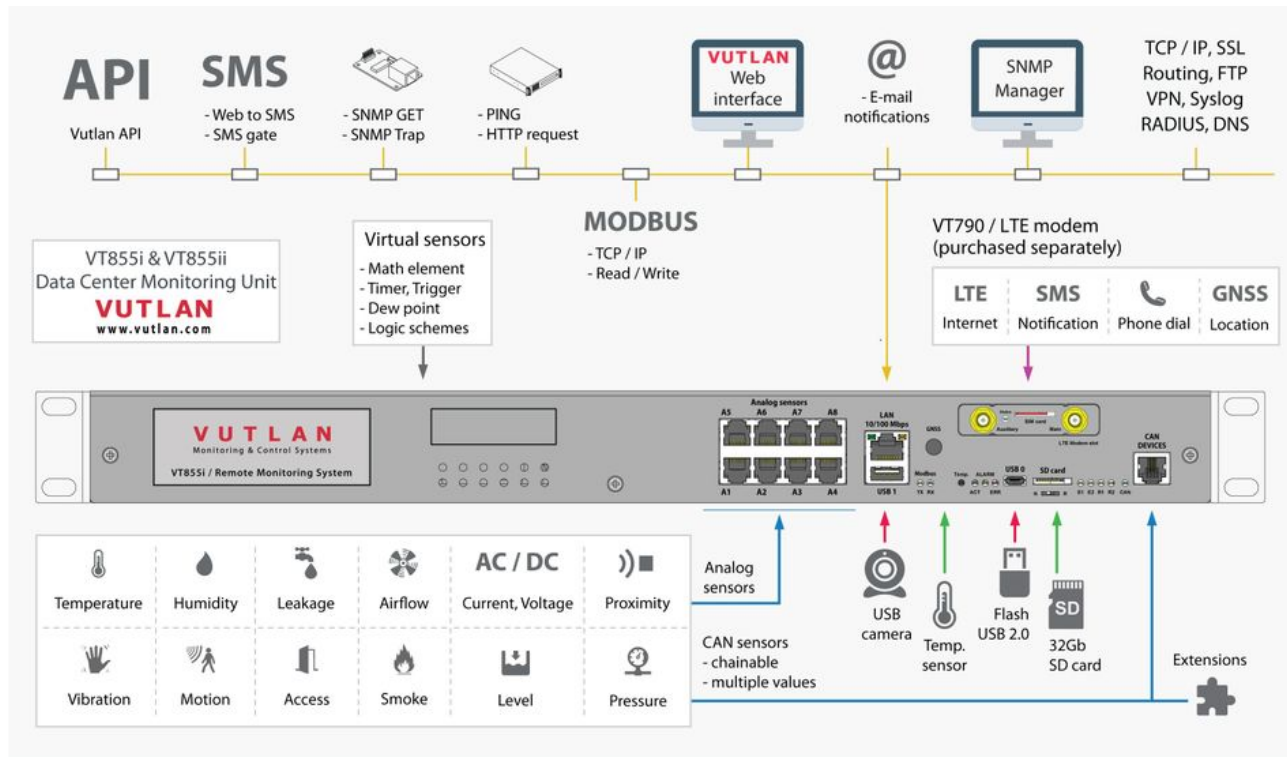

The back panel of VT855ii:

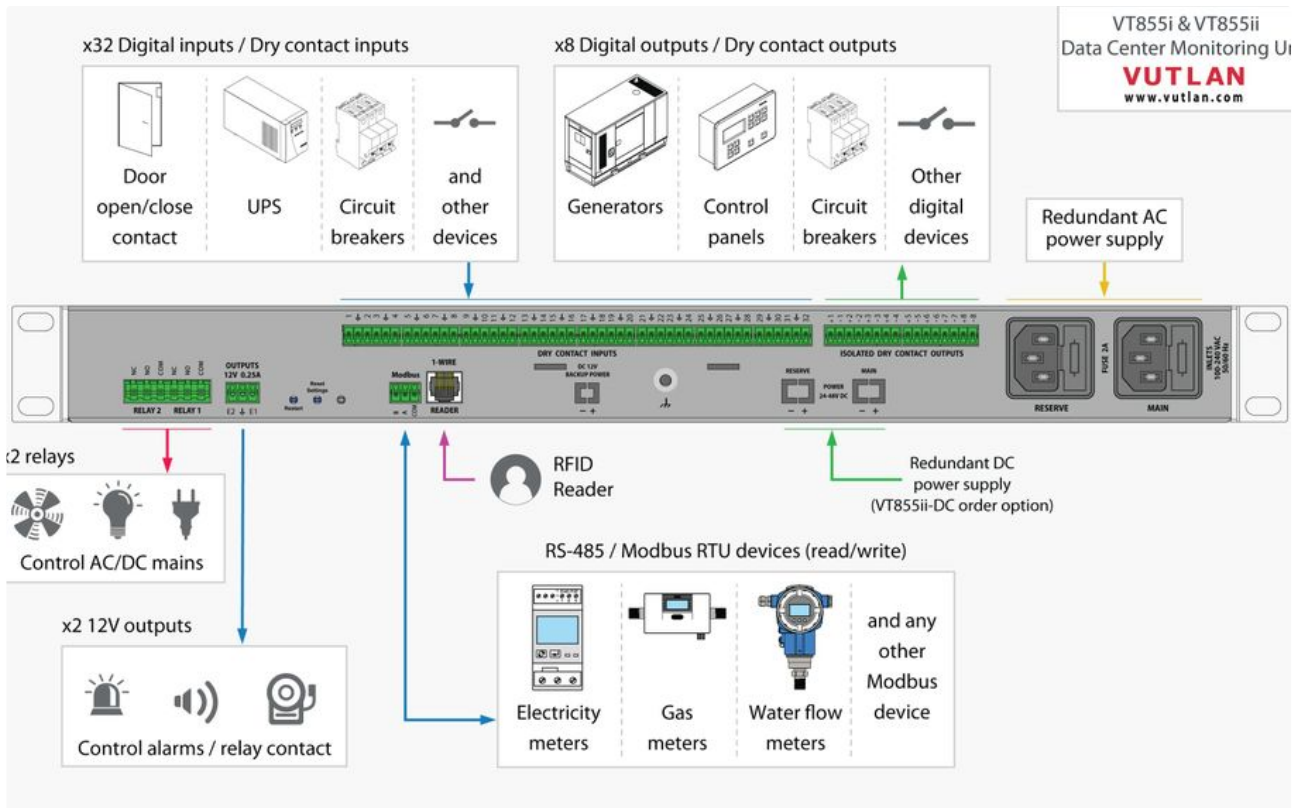

Drawing dimensions

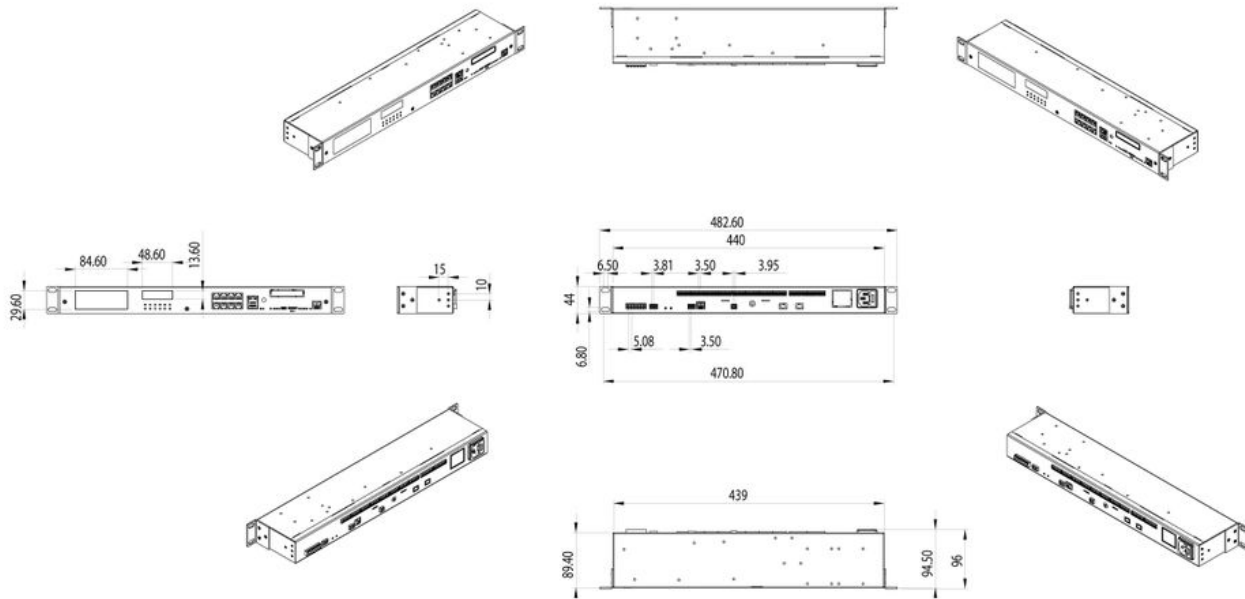

Installing the device into a 19" rack

Use x3 pcs of supplied screws (M3 6mm) for each bracket to fix it on each side of the enclosure as shown in the picture below. The screws and brackets are supplied with the unit.

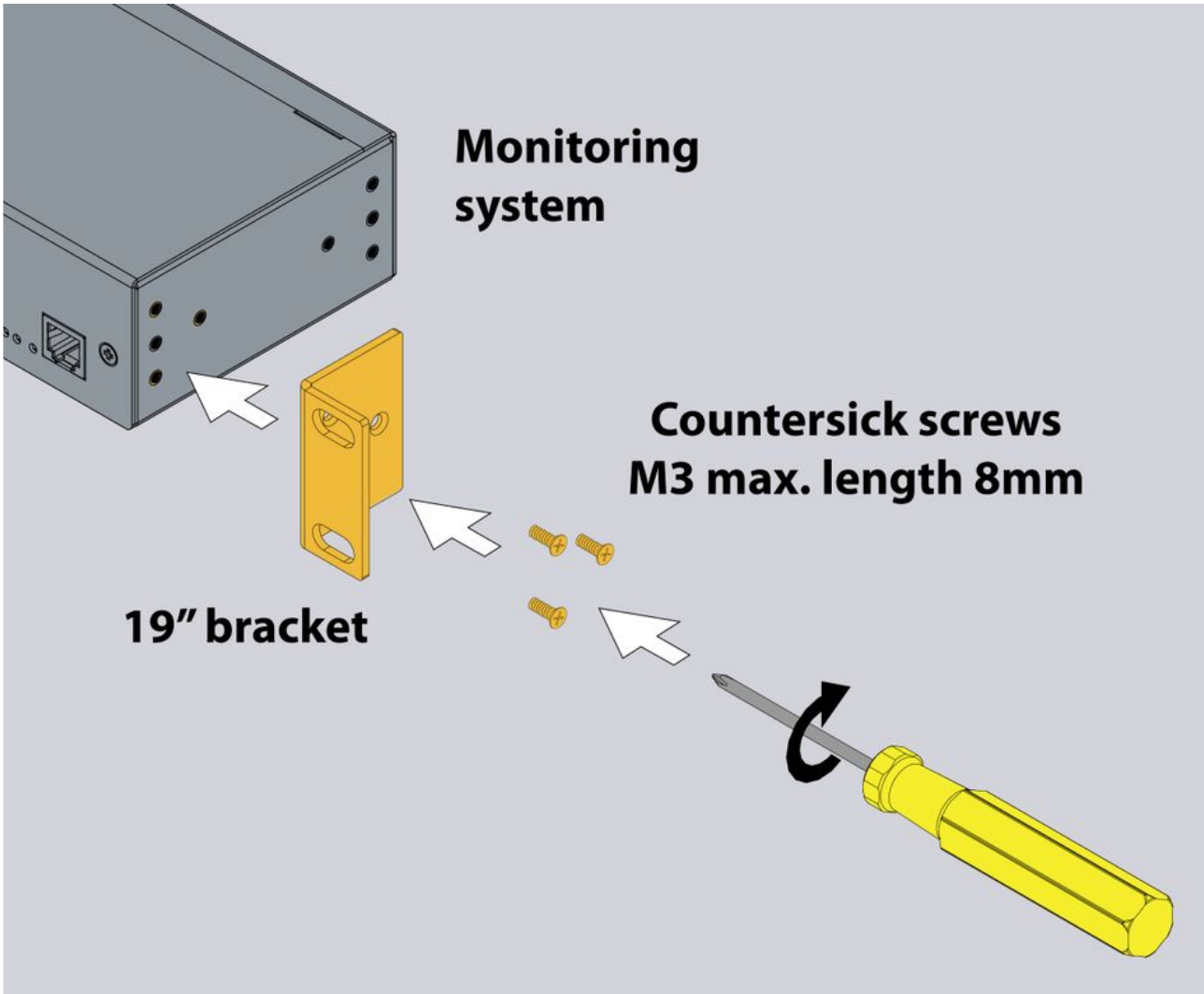
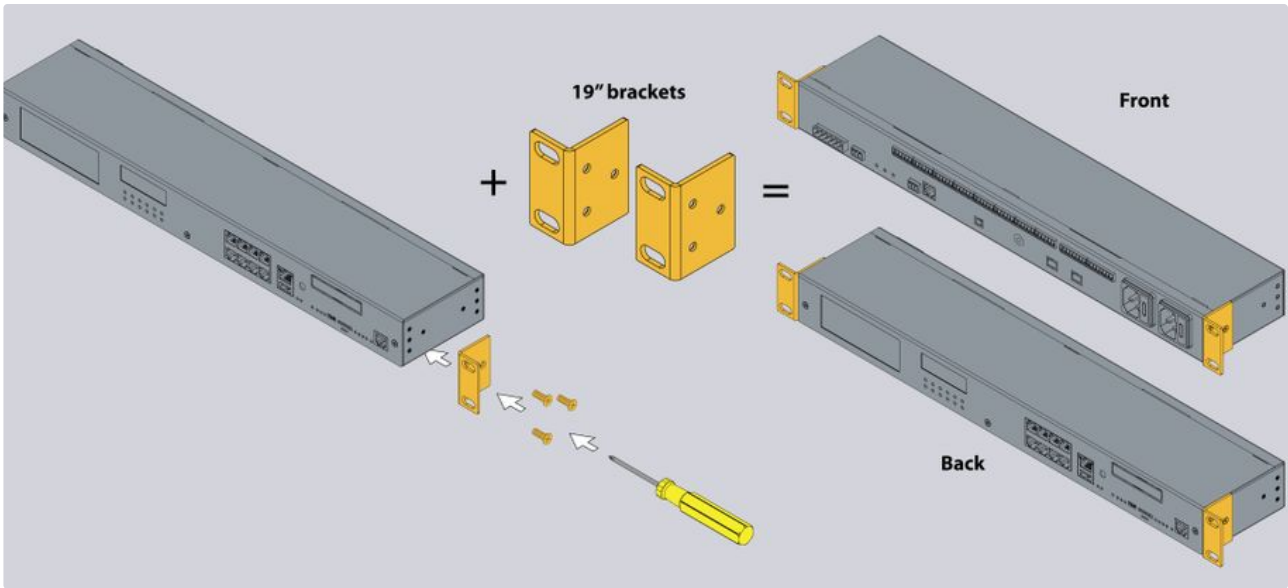

Installing LTE slot modem

Product page: <https://vutlan.com/modems/165-vt740-lte-slot-modem.html>



Usage

Can be installed in VT335i , VT825i, VT825ii, new VT825DC, VT825DCDC, VT825iDC, VT855i, VT855ii, VT855DC, VT855iDC, VT960i v3, VT960ii v3, monitoring systems.

Inventory

Make sure that the contents of the delivery meet the following configuration. Report a missing or damaged component to your supplier. If damage occurred during transportation, contact the appropriate delivery service.

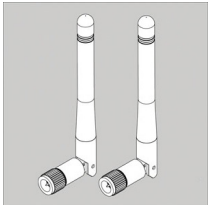
	Package content	Description	Quantity
1		LTE modem board 2pcs SMA antenna connectors 1 pc metal plate	
2		LTE antennas	2 pcs

Developer notes:

Description

4G LTE slot modem for Vutlan monitoring units. Allows to receive and send SMS messages. Provides Ethernet over 4G LTE. Power-cycling is an embedded function.

Panel

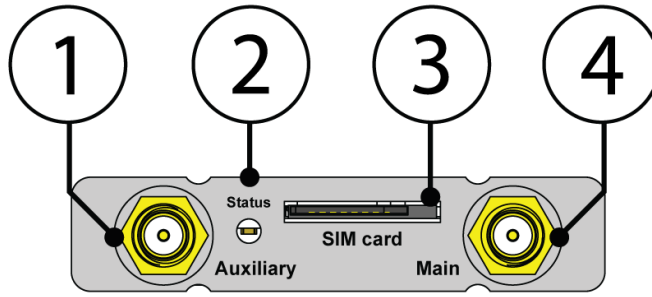

1. **"Auxiliary"** - Connector, used when the modem is installed inside of the appliance to connect LTE auxiliary antenna. The additional antenna helps to strengthen the signal level. (Auxiliary LTE antenna is supplied together with the modem).
2. **"Status"** - displays modems status. Blinking = working.
3. **"SIM card"** - SIM card slot with an injector.
4. **"Main antenna"** - Connector, used when the modem is installed inside of the appliance to connect LTE main antenna. (The main antenna is supplied together with the modem).

ⓘ VT740 has a miniature RF connector on the board for connecting GNSS antenna. GNSS antenna is not sold together with VT740.

Installation

You can install the modem while the system is turned On. You may wait up to 3 minutes until the Telecom operator information is renewed.

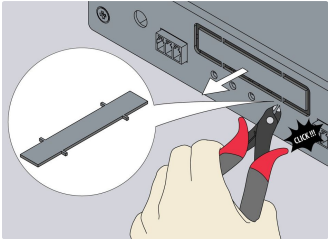
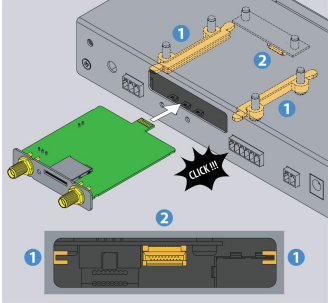
Step 1		<p>1.1 Use the wire cutter tool to cut off the metal panel labeled "LTE Modem slot".</p> <p>You can dispose of the metal panel after.</p>
Step 2		<p>Plug the VT740 slot modem as shown on the picture into the opening. The board should slide into the guide rails (marked as "1") and plug into the jack (marked as "2").</p>

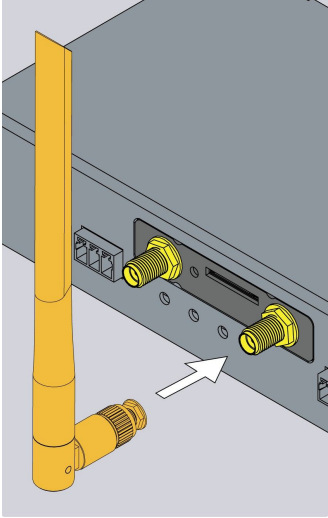
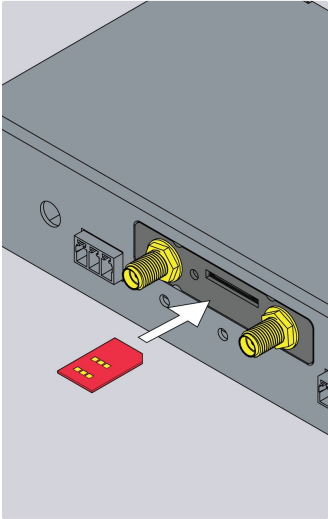
Step 3		<p>3.1 Screw the main LTE antenna into "Main" antenna" jack.</p> <p>3.2 If you want to strengthen the signal, you can screw in the second auxiliary antenna into "Auxiliary" jack.</p>
Step 4		<p>Plug in the SIM card. The SIM card slot has an injector.</p>
Step 5		<p>You are ready to go! Turn on the system.</p> <p>You can install the modem while the system is turned On. You may wait up to 3 minutes until the Telecom operator information is renewed.</p>

Configuring the modem

Please read the following section for the configuration instructions:

Online documentation page link: [Setting up a modem](#)

The direct page link for users with paper documentation:

<https://vutlan.atlassian.net/wiki/spaces/DEN/pages/1016347/Setting+up+a+modem>

Modem errors:

Problem	Cause	Solution
---------	-------	----------

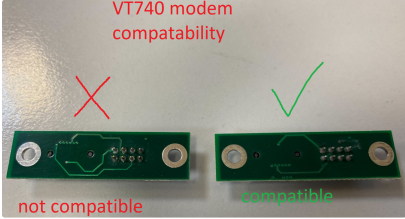
<p>Modem is not initializing. Power light status is not working.</p>	<ol style="list-style-type: none"> 1. The cable has disconnected due to transportation. 2. The unit is not updated to the latest driver version. 3. An incorrect converter board is installed inside the unit by mistake. 	<ol style="list-style-type: none"> 1. Power down the device. Open the unit's case. Check the cable is connected. 2. Please, update the unit to the latest version. 3. Check if you have a correct converter board installed inside the unit. 
--	--	---

Inventory

Make sure that the contents of the delivery meet the following configuration. Report a missing or damaged component to your supplier. If damage occurred during transportation, contact the appropriate delivery service.

	Package content	Description	Quantity				
			VT855i	VT855ii	VT855iDC	VT855DC	VT855DCDC
1		Monitoring unit VT855.	1 pc				
2		OTG Micro USB cable adapter	1 pc				
3		RJ-45 3m patch cable. For LAN Ethernet connection.	1 pc				
4		Self-adhesive rubber foot	4 pcs				
5		19" rack brackets	2 pcs				

6		M3 x 8mm Phillips flat-head screws	6 pcs				
7		Configuration manual	1 pc				
8		Warranty card	1 pc				
9		Terminal plug 6 pins, 5.08mm, 6P. For NC NO COM relays.	1 pc				
10		Terminal plug 3 pins, 3.81 mm. For 12V relays (E1 & E2).	1 pcs				
11		Terminal plug 3 pins, 3.5 mm. For Modbus port.	1 pcs				
12		Terminal plug 6 pins, 3.5 mm. For connecting dry contact inputs.	8 pcs				
13		Terminal plug 8 pins, 3.5 mm. For connecting dry contact outputs.	2 pcs				
			VT855i	VT855ii	VT855iDC	VT855DC	VT855DCDC
14		Terminal plug 2 pins, 5.08mm, 2P. For power input 24-48VDC.	-	-	1 pc	1 pc	2 pc
15		EL Schuko C13 0.75 mm² 230V 10A cable	1 pc	2 pc	1 pc	-	-

Technical details

VT325, VT335i, VT336, VT825i, VT825ii, VT855i, VT855ii, VT960i, VT960ii are the monitoring units and can not connect to each other. For scalability please use extension units and embedded boards. All units except produced in DC / DC version.

- Built-in
- None
- ◆ Extension possible
- ◇ Not extendable

Versions	VT960i / VT960ii DC/DC; AC/DC	VT855i / VT855ii DC/DC; AC/DC	VT825i / VT825ii DC/DC; AC/DC	VT335i	VT336	VT325
Device Management: Web, SNMP, manually via SMS	Yes	Yes	Yes	Yes	Yes	Yes
<hr/>						
Interface	VT960i	VT855i	VT825i	VT335i	VT336	VT325
LAN: Ethernet 10/100 Mbit	Yes	Yes	Yes	Yes	Yes	Yes
OS: Linux	v.5.10	v.5.40	v.5.40	v.5.40	v.3.10	v.3.10
RAM:	1Gb	128Mb	128Mb	64Mb	64Mb	64Mb
CPU speed:	720mHz	600mHz	600mHz	600mHz	300mHz	300mHz
Total CPU cores:	4	1	1	1	1	1
Clock: Built-in clock	Yes	Yes	Yes	Yes	Yes	Yes
Watchdog: Built- in watchdog timer						
Max. amount of sensors: physical sensors, dry contacts, relays	400	150	150	100	30	6
Max. amount of elements: notifications, triggers, timers, logic, sensors, dry contacts, SNMP Get, SNMP Trap, Dial task, and other elements	2000	1000	1000	700	500	500
<hr/>						
Protocol support	VT960i	VT855i	VT825i	VT335i	VT336	VT325

Network protocols: DHCP; HTTP; HTTPS; DynDNS; SSL; SNMP v1, v2c, v3; SMTP; FTP; Syslog; RADIUS; OpenVPN	Yes	Yes	Yes	Yes	Yes	Yes
Modbus RTU	Yes	Yes	No	No	Yes	No
VPN: secure data communications; secure change of connection between LTE and LAN	Yes	Yes	Yes	Yes	Yes	Yes
Alerts / Notifications	VT960i	VT855i	VT825i	VT335i	VT336	VT325
Alert types: E-mail, FTP log, Syslog, SMTP, SNMP Traps, SMS (Modem is ordered separately), Web-to-SMS,	Yes	Yes	Yes	Yes	Yes	Yes
A maximum number of "mail to" recipients in an E-mail notification:	50	20	20	20	10	10
A maximum number of "SMS to" recipients in an SMS notification: also the maximum amount of phone numbers	50	20	20	20	10	10
Virtual sensors	VT960i	VT855i	VT825i	VT335i	VT336	VT325
Pings: Built-in function for server pinging. Test the reachability of a host in a network.	Yes	Yes	Yes	Yes	Yes	Yes

IP cameras: Connect the IP MJPEG camera with a proxy via the master module. Only view, no record.	4	4	4	4	4	4
Get SNMP: Read data from external equipment via SNMP PDU GET (v1/2c)	Yes	Yes	Yes	Yes	Yes	Yes
User keys: Add users who have access using an RFID reader.	Yes	Yes	Yes	No	Yes	Yes
Logic schemes: Used to specify automatic actions to events that occur in the system.	Yes	Yes	Yes	Yes	Yes	Yes
Timers: Allows you to plan the events in the system.	Yes	Yes	Yes	Yes	Yes	Yes
Triggers: Generate events in the system if logic is triggered.	Yes	Yes	Yes	Yes	Yes	Yes
SNMP traps	Yes	Yes	Yes	Yes	Yes	Yes
Virtual Math element (combine several sensor data and calculate new data)	Yes	Yes	Yes	Yes	Yes	Yes
Logic schemes	Yes	Yes	Yes	Yes	Yes	Yes
Modbus TCP/IP: read / write	Yes	Yes	Yes	Yes	Yes	Yes
Power	VT960i	VT855i	VT825i	VT335i	VT336	VT325
Power input:	90-230V	90-230V	90-230V	12V	12V	12V
Power input DC:	24 ÷ 48V	24 ÷ 48V	24 ÷ 48V	12V	□	□
Fuse: Fuse at the inlet	1A	1A	1A	1A	□	□

Max. power consumption:	30W	30W	10W	10W	12W	6W
The maximum current load on the relay:	10A	10A	10A	250mA	250mA	250mA
Redundant power supply: built-in voltage monitor, voltage range 9-12.6V.	Yes AC/DC DC/DC	Yes AC/DC DC/DC	Yes AC/DC DC/DC	Yes DC 12V	□	□
Outputs						
	VT960i	VT855ii	VT825i	VT335i	VT336	VT325
Relay outputs: latching relays 240V*10A	2	2	2	□	□	□
Relays outputs: 12V 0.25A	2	2	2	2	2	2
Max. dry contact outputs (contact closures/digital outputs)	8	8	□	□	□	□
Audio output: AV OUT	1	□	□	□	□	□
Video output: AV OUT	1	□	□	□	□	□
Inputs						
	VT960i	VT855i	VT825i	VT335i	VT336	VT325
Analog port: 6P6C for connection of an analog sensor.	8 built-in ports, up to 16 on CAN bus extension unit	8 built-in ports, up to 16 on CAN bus extension unit	8 built-in ports, up to 16 on CAN bus extension unit	4 built-in ports, up to 16 on CAN bus extension unit	6 built-in ports, up to 16 on CAN bus extension unit	2 built-in ports only
CAN port: Max number of sensors Use CAN-12V-1A for connecting more than 12 devices.	32	32	32	32	20	□
Dry contact inputs:	up to 32 on built-in extension, up to 64 on CAN bus Dry contacts unit	up to 32 on built-in extension, up to 64 on CAN bus Dry contacts unit	up to 32 on built-in extension, up to 64 on CAN bus Dry contacts unit	4 built-in, up to 64 on CAN bus Dry contacts unit	4 built-in, up to 64 on CAN bus Dry contacts unit	2 built-in only

Modbus RTU (RS-485): Max. line length 1000m	1 built-in port, up to 50 sensors	1 built-in port, up to 50 sensors	<input type="checkbox"/>	<input type="checkbox"/>	1 built-in port, up to 50 sensors	1 port by Modbus extension board
Reader 1-Wire	1 built-in port	1 built-in port	<input type="checkbox"/>	<input type="checkbox"/>	<input type="checkbox"/>	1 port by 1-Wire extension board
Video	VT960i	VT855i	VT825i	VT335i	VT336	VT325
Video cameras:	AV, x2 USB, x4 IP	USB, x1 IP	USB, x1 IP	USB, x1 IP	USB, x1 IP	USB, x1 IP
Video power supply: DC 12V 0,25A for analog camera	Yes	<input type="checkbox"/>	<input type="checkbox"/>	<input type="checkbox"/>	<input type="checkbox"/>	<input type="checkbox"/>
Other connectors	VT960i	VT855i	VT825i	VT335i	VT336	VT325
Ethernet port: 10/100Mbit	Yes	Yes	Yes	Yes	Yes	Yes
USB 2.0 Type A	1	1	1	<input type="checkbox"/>	<input type="checkbox"/>	<input type="checkbox"/>
USB 2.0 micro	1	1	1	1	1	1
Switch Normal / Recovery: returns the device to factory settings	<input type="checkbox"/>	Yes	Yes	Yes	Yes	Yes
FEL button: softly restarts the SATA drive	Yes	<input type="checkbox"/>	<input type="checkbox"/>	<input type="checkbox"/>	<input type="checkbox"/>	<input type="checkbox"/>
Shutdown button: Softly shuts down the device.	Yes	<input type="checkbox"/>	<input type="checkbox"/>	<input type="checkbox"/>	<input type="checkbox"/>	<input type="checkbox"/>
External Memory	VT960i	VT855i	VT825i	VT335i	VT336	VT325
SD card slot (SDHC up to 32Gb)	Yes	Yes	Yes	Yes	No	No
SD card slot (SDXC up to 128Gb)	Yes	Yes	Yes	Yes	No	No
SD card formatting function (FAT32)	Yes	Yes	Yes	Yes	No	No

SATA Drive: 2.5" HDD or SSD (ordered separately)	Yes	No	No	No	No	No
Extensions (modules are ordered separately)	VT960i	VT855i	VT825i	VT335i	VT336	VT325
SATA: 2.5" HDD or SSD (ordered separately)	Yes	No	No	No	No	No
Modem (extensions)	VT960i	VT855i	VT825i	VT335i	VT336	VT325
4G LTE modem: ordered separately.	VT790	VT740	VT740	VT740	VT770	□
Modem modes: <ul style="list-style-type: none"> Gateway: Internet access Access: Internet access over LTE SMS: SMS notifications 	Gateway / Access / SMS	Gateway / Access / SMS	Gateway / Access / SMS	Gateway / Access / SMS	Access / SMS	SMS (external modem)
Embedded onboard sensors	VT960i	VT855i	VT825i	VT335i	VT336	VT325
Temperature sensor: +/- 1 °C Case temperature.	Yes	Yes	Yes	Yes	Yes	Yes
Power supply voltage sensor: Accuracy (1%)	1	Main & Reserve	Main & Reserve	Main & Reserve	1	1
Alarm LED: Programmable LED	No	Yes	Yes	Yes	No	No
Analog sensor power reset: resets smoke sensors	Yes	Yes	Yes	Yes	Yes	Yes

Environmental characteristics	VT960i	VT855i	VT825i	VT335i	VT336	VT325
Operating temperature: -10 to 80 °C	Yes	Yes	Yes	Yes	Yes	Yes
Storage temperature: -25 to 85 °C	Yes	Yes	Yes	Yes	Yes	Yes
Operating humidity: 0 to 90 %, non-condensing	Yes	Yes	Yes	Yes	Yes	Yes
Storage humidity: 0 to 95 %, non-condensing	Yes	Yes	Yes	Yes	Yes	Yes
Other Features						
Other Features	VT960i	VT855i	VT825i	VT335i	VT336	VT325
Installation:	19" 1U	19" 1U	19" 1U	Desktop	DIN rail	Desktop
Dimensions (L x W x H) in mm:	440*44*120	440*44*90	440*44*90	180*35*80	160*90*58	95*35*80
Weight:	2 kg	1,5 kg	1,5 kg	0,7 kg	0,4 kg	0,4 kg
External chassis grounding: M4 thread	Yes	Yes	Yes	Yes	□	Yes
Web interface (panels)						
Web interface (panels)	VT960i	VT960ii	VT855i	VT335i	VT336	VT325
Dashboard panel:	Yes	Yes	Yes	Yes	Yes	Yes
Overall statistics panel:	Yes	Yes	Yes	Yes	Yes	Yes
System tree panel: sensors and devices displayed in a hierarchy	Yes	Yes	Yes	Yes	Yes	Yes
Dry outputs panel:	wth VTx32 extension	wth VTx32 extension	Yes	No	Yes	No
Dry inputs panel:	Yes	Yes	Yes	Yes	Yes	Yes
Event log panel:	500 logs	300	300	300	200	200
Logic scheme panel:	Yes	Yes	Yes	Yes	Yes	Yes
Cameras panel:	Yes	Yes	Yes	Yes	Yes	Yes
Map panel:	Yes	Yes	Yes	Yes	Yes	Yes

Users panel:	Yes	Yes	Yes	Yes	Yes	Yes
CAN configuration panel:	Yes	Yes	Yes	Yes	Yes	No
Graphs panel:	Yes	Yes	Yes	Yes	Yes	Yes
Reset smoke detectors panel:	Yes	Yes	Yes	Yes	Yes	Yes
Preferences panel: Web GUI, Network, Time, Logging, DynDNS, SNMP, RADIUS, FTP backup, VPN Client, Modbus RTU, GPS, SMTP, Routing						
System menu panel: About, Firmware, Export, Support	Yes	Yes	Yes	Yes	Yes	Yes
List of latest sent SMS messages:	500	200	200	150	100	100
Supported Vutlan environmental sensors						
Temperature, Outdoor Temperature, Humidity, Water leakage, Wind speed meter, Access sensor, Door sensor, Water Level, AC / DC current meters, AC voltage monitor, Smoke detector, Vibration, Motion / PIR, Converter	Yes	Yes	Yes	Yes	Yes	Yes

- Built-in
- None
- ◆ Extension possible
- ◇ Not extendable

Copyright:

Vutlan s.r.o. (LLC)

Remote Infrastructure Monitoring and Control

43 ul.Svornosti, 821 06 Bratislava,

Slovak Republic

www.vutlan.com